

美的吸尘器 使用说明书

VACUUM CLEANER OPERATION INSTRUCTIONS MANUAL

C5 PRO (C5-L121D)

江苏美的清洁电器股份有限公司

 通讯地址：苏州市相城经济开发区漕湖大道39号 邮政编码：215000

 400-8899-315   www.midea.com

 执行标准：GB4706.7-2014 / GB4706.1-2005 / GB4343.1-2009 / GB17625.1-2012
版本号：C5-L121D10-06-R4.2

Jiangsu Midea Cleaning Appliance Co.,Ltd

 Address：No.39 Caohu Avenue, Xiangcheng Economic Development Zone, Suzhou Post：215000

 400-8899-315   www.midea.com

 Executive standard：GB4706.7-2014 / GB4706.1-2005 / GB4343.1-2009 / GB17625.1-2012
Version No.：C5-L121D10-06-R4.2



使用产品前请仔细阅读本说明书，并请妥善保管

Please read this Instruction Manual carefully before operating, and keep it properly.

目录

Contents

产品介绍	Product Introduction	2
使用说明	Product Operation	4
维护保养	Product Maintenance	7
异常处理	Trouble Shooting	8
安全说明	Safety Introduction	12
保修须知	Warranty Introduction	14

产品介绍

Product Introduction

- ① 主机 Main body
- ② 软管 Hose
- ③ 伸缩金属管 Extension tube
- ④ 主地刷 Main brush
- ⑤ 风动地刷 Turbo brush
- ⑥ 关节式毛刷 Joint-type brush
- ⑦ 三合一组合吸刷 Three-in-one brush
- ⑧ 宠物刷 Pet brush

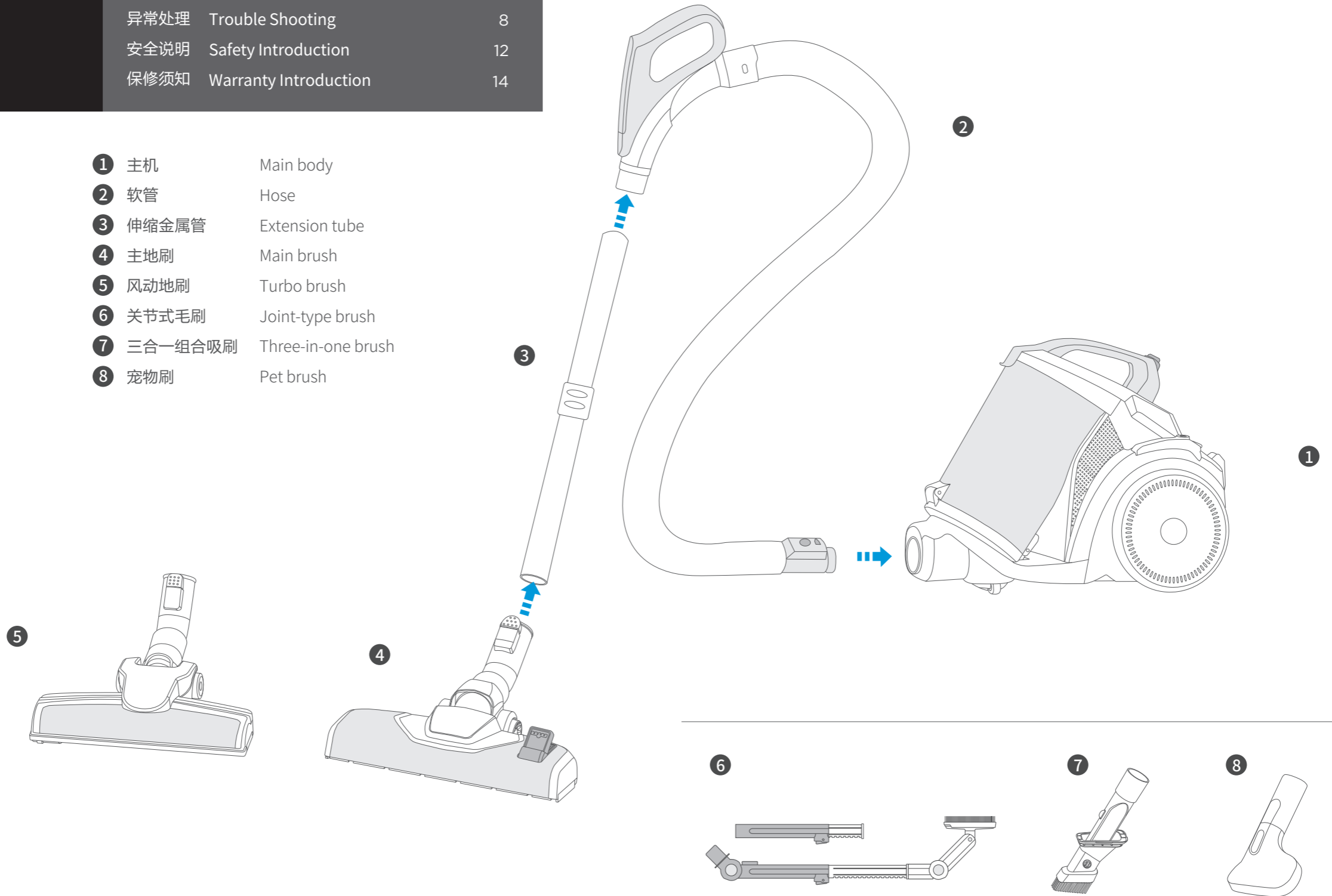

使用说明 Product Operation

主机图解

Illustration of the main unit

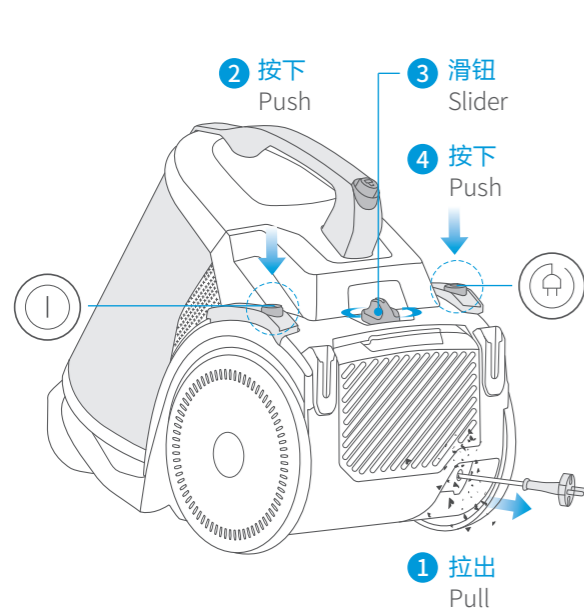

- 01. 拉出电源线连接电源：**当看到电源线红色标记时，请不要再向外拉电源线。
Pull out the power cord to connect the power supply : When you see the red mark on the power cord, do not pull the power cord outward.
- 02. 按下开关按钮：**控制吸尘器的启动与停止。
Press the ON/OFF button : Control the start and stop of the vacuum cleaner.
- 03. 调节吸力：**左右滑动调速滑钮调节吸力大小。对于地毯和地板，使用大吸力；对于窗帘、桌布等物品时，使用小吸力。
Adjust the suction : Adjust the suction magnitude by moving the slider left or right. Use large suction for carpets and flooring. Use small suction for curtains, tablecloths and other items.
- 04. 按下收线按钮：**电源线自动卷回机身内。
Press the take up button : The power cord is automatically rolled back into the machine.

⚠ 注意 Caution

请缓慢收线，避免电源线或电源插头在收线过程中打伤人体或家具。

Please slowly take up the cord, to avoid the power cord or power plug bruising human body or furniture in the process of taking up.

其他附件说明

配件使用

Other accessories

Use of accessories

主地刷

Main brush

地刷踏板踏下，伸出刷毛时可进行地板吸尘；地刷踏板再次踏下，缩进刷毛时可进行地毯吸尘。

Step down the pedal of main brush, collect the dust deposited on floor when the bristles are extending. When step down the pedal again, collect the dust deposited on carpet when bristles retract.

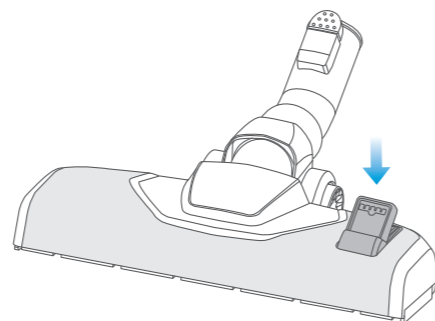

风动地刷

Turbo brush

当风动地刷滚刷需要清理或更换时，可用手拉出右侧挡块，拆卸滚刷条，清理地刷内的头发等异物，以便不影响风动地刷的正常使用。

When the brush roller of turbo brush needs to be cleaned or replaced, you can remove the brush roller by pulling the right block by hands, and clean the hair and other foreign matters in the brush for the normal use of the turbo brush.

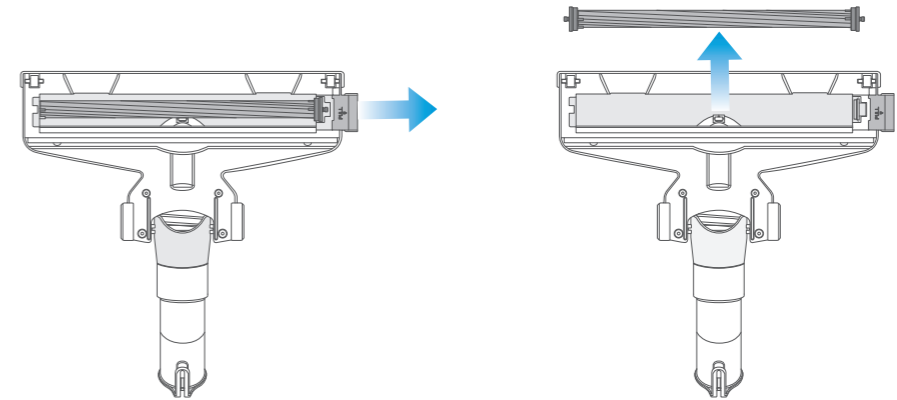

关节式毛刷

Joint-type brush

关节式毛刷适合吸除窗缝、家具缝、角落、天花板等小缝隙处的灰尘或短毛布艺家具处的灰尘以及一般工具无法到达的地方，可根据需求转动刷头、调节前后关节、伸缩扁吸嘴，以满足不同方向及角度的清扫。

Joint-type brush is design for suction of dust at the window joints, furniture seam, corners, ceilings and other small gaps or that at the short-hair fabric furniture as well as places that are inaccessible. The cleaning for different directions and angles by rotating brush head, adjusting the front and rear joints and extending the flat suction nozzle.

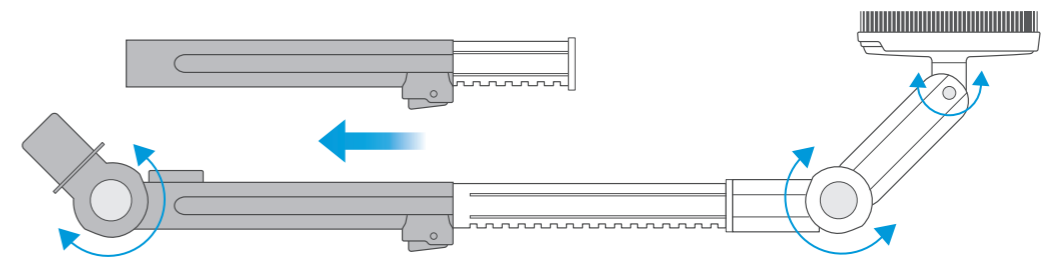

使用说明 Product Operation

宠物刷

提示：适用于中等长度或长毛的宠物。

Pet Brush

Tips: Suitable for medium or long haired pets.

宠物刷连接软管，接通整机工作。

Connect the pet brush to the soft tube, and turn on the unit work.

在梳理过程中收集散落的宠物毛发，只需松开按键，就可以将毛发从刷毛上吸入吸尘器中。

Collect loose pets' hair during grooming. Simply release trigger to remove hair from the bristles and into the vacuum.

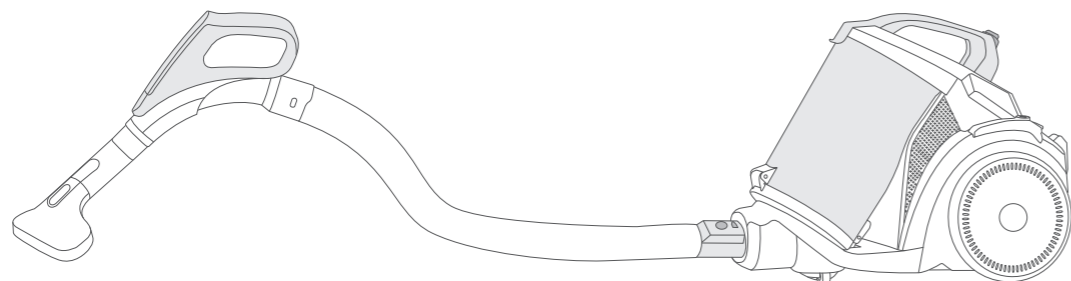

宠物刷使用前请务必测试宠物对于整机声响的敏感性，以及宠物对刷子使用力度的适应性，避免宠物受到惊吓，带来不必要伤害。

Please test the sensibility of the pet to the noise and the adaptability of the force before using, to avoid scaring the pets, or cause unnecessary hurts.

维护保养 Product Maintenance

尘杯清洁

Dust cup cleaning

01. 卸下尘杯：按下尘杯释放键，轻轻提拉尘杯提手，取出尘杯。
Remove the filter container for cleaning: open the dust cup, remove the filter button and clean it.

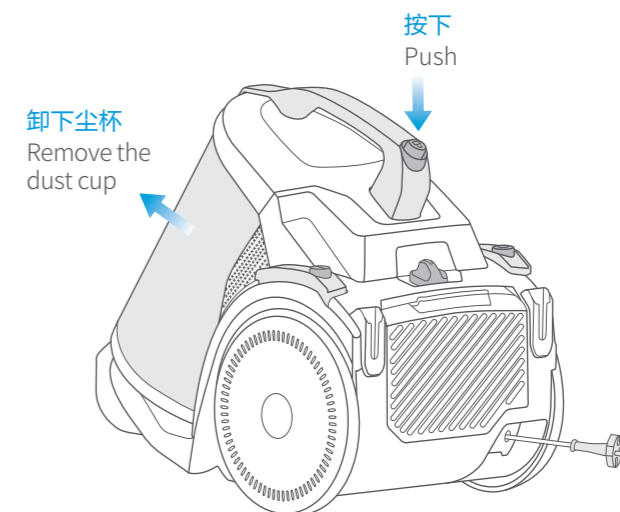

02. 倾倒垃圾：轻按倒尘按钮，倾倒垃圾。
Dump the garbage: Tap the dust dumping button to dump the garbage.



维护保养 Product Maintenance

尘杯维护保养

Dust cup maintenance

01. 打开尘杯：轻提尘杯开启按钮，然后向上提起即可打开尘杯盖。

Open the dust cup: Gently lift the dust cup open button, and then lift up to open the dust cup cover.



02. 取出过滤棉清洁：打开尘杯后取出过滤棉并清洁即可。

Remove the filter cotton and whirlwind cone. Clean the whirlwind cone and beat the filter cotton down. (Do not beat along the reverse).



03. 过滤芯拆卸，过滤芯清洗：向上提出滤芯并拆下滤芯下盖，将过滤芯、过滤芯下盖放在水龙头下冲洗。

Filter disassembly and cleaning: Raise the filter and remove the filter cover, put the filter and its bottom cover under the faucet for washing.

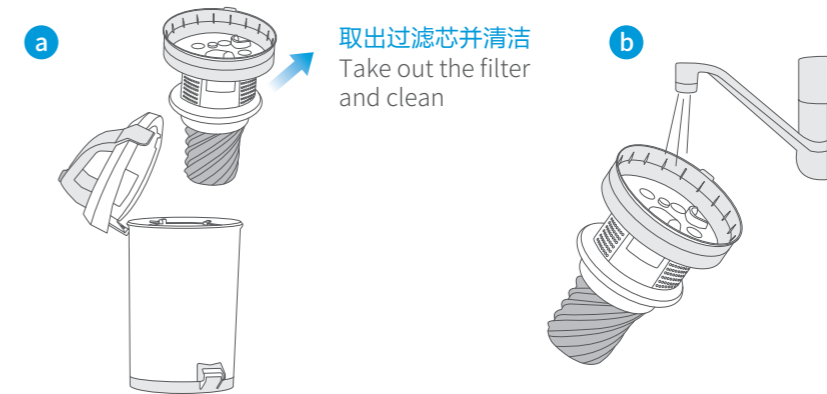

04. HEPA清洗：按图示打开出风板，取出HEPA后清洗即可。

HEPA cleaning: Open the air foil as shown in figure below, and clean after removing the HEPA.

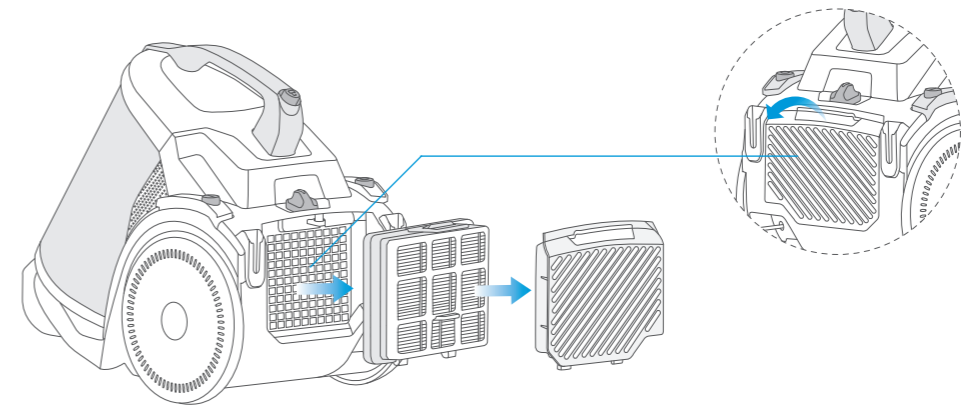

⚠ 注意 Caution

各过滤部件清洗后必须干燥后才可装回使用，建议阳光下晒24小时确保彻底干燥后再使用；必须确保各部件安装到位，否则会引起产品故障；不可将水渗入吸尘器电器元件内，否则可能会引起产品故障。

The filter parts can be put back for use only after being cleaned and dried. It is recommended to have sun exposure for 24 hours to ensure it is thoroughly dried. All parts must be ensured to be properly installed, otherwise it will cause product failure. Water is not allowed to penetrate into the vacuum cleaner electrical components, or otherwise may cause product failure.

异常处理

本品在使用时如发现异常，请先查阅下表。

异常情况	可能原因	处理方法
吸尘器全部工作	<ul style="list-style-type: none"> - 电源插头未在插座上插牢 - 电源插座没有电 - 吸尘器开关没有打开 - 电机热保护器动作 	<ul style="list-style-type: none"> - 重新插入插头 - 检查断路器 - 按下机器的电源开关 - 拔掉插头，等待热保护器恢复
吸力减弱	<ul style="list-style-type: none"> - 主地刷或附件吸头堵塞 - 尘桶中的灰尘过满 - 尘杯过滤棉灰尘过多 - 出风HEPA灰尘过多 	<ul style="list-style-type: none"> - 清理堵塞物 - 及时清理垃圾 - 清洗尘杯过滤棉 - 清洗出风HEPA

其他无法处理的故障，请联系当地售后服务网点或拨打全国服务热线：400 8899 315

中国RoHS



零部件名称	中国RoHS管控物质或元素					
	铅	汞	镉	六价铬	多溴联苯	多溴二苯醚
电子电路	×	○	○	○	○	○
开关	○	○	○	○	○	○
电源线	×	○	○	○	○	○
电机组件	○	○	○	○	○	○
电机罩组件	○	○	○	○	○	○
金属伸缩管	○	○	○	○	○	○
软管组件	○	○	○	○	○	○
附件组件	○	○	○	○	○	○
出风板组件	○	○	○	○	○	○
尘杯组件	○	○	○	○	○	○
中框组件	○	○	○	○	○	○
机体组件	○	○	○	○	○	○
过滤组件	○	○	○	○	○	○

备注：

1. 本表格依据SJ/T 11364的规定编制。
2. ○：表示该有害物质在该部件所有均质材料中的含量均在GB/T 26572规定的限量要求以下。
3. ×：表示该有害物质至少在该部件的某一均质材料中的含量超出GB/T 26572规定的限量要求。
4. 本表中的有×的所有部件均符合欧盟的RoHS指令，即“欧洲议会和理事会关于在电子电气设备中限制使用某些有害物质的第2011/65/EU号指令”及其修正案。

TROUBLESHOOTING

In case of mis-function, please refer to the following table

Problem	Possible causes	Solution
The vacuum cleaner does not work	<ul style="list-style-type: none"> - The power plug is not properly plugged into the socket - No electricity on the power socket - The vacuum cleaner switch is not turned off - Motor thermal protector acts 	<ul style="list-style-type: none"> - Reinsert the plug - Check the circuit breaker - Press the machine's power switch - Unplug the plug and wait for the thermal protector to recover
Suction becomes weaker	<ul style="list-style-type: none"> - The main brush or accessories are clogged - Dust in the dust barrel is too full - Dust in the dust cup filter cotton is too much - Dust in the exhaust HEPA is too much 	<ul style="list-style-type: none"> - Clean up the stemming - Timely clean up garbage - Clean the filter cotton of dust cup - Clean the exhaust HEPA

For other failures, please contact the local service outlet or call the service hotline : 400 8899 315

CHINA RoHS



Component name	China's RoHS control substances or elements					
	(Pb)	(Hg)	(Cd)	(Cr(VI))	(PBBs)	(PBDEs)
Electronic circuit	×	○	○	○	○	○
Switch	○	○	○	○	○	○
Power cord	×	○	○	○	○	○
Motor assembly	○	○	○	○	○	○
Motor cover assembly	○	○	○	○	○	○
Metal extension tube	○	○	○	○	○	○
Hose assembly	○	○	○	○	○	○
Accessory assembly	○	○	○	○	○	○
Air-out board assembly	○	○	○	○	○	○
Dust cup assembly	○	○	○	○	○	○
Mullion assembly	○	○	○	○	○	○
Body assembly	○	○	○	○	○	○
Filter assembly	○	○	○	○	○	○

Remarks:

1. This table is formulated based on the provisions of SJ / T 11364.
2. ○：Indicates that the content of this hazardous substance in all the homogeneous materials of the part is lower than the limit requirement prescribed in GBSJ / T 26572.
3. ×：Indicates that the content of this hazardous substance in a certain homogeneous material of the part has exceeded the limit requirement prescribed in GB/T 26572.
4. All the parts with * in this form are in accordance with EU RoHS instructions, namely "No. 65/2011 / EU Instruction of European Parliament and Council on Restrictions on the Use of Certain Hazardous Substances in Electrical and Electronic Equipment" and its amendment.

安全说明



- 请勿将吸尘器接近热源，辐射或者燃烧的烟头，严禁吸入下列物体，
 1. 水及溶剂等一切液体。
 2. 石灰、水泥灰等建筑粉尘及垃圾。
 3. 发热物体，如未熄灭碳头、烟头。
 4. 锐利碎片，如玻璃等。
 5. 易燃易爆物品，如汽油或酒精制品。
- 切勿让小孩玩弄、操作吸尘器，以免发生意外；
- 您的吸尘器是一台电动器具：它必须按照正常使用条件进行使用，切莫让吸尘器在无人看管情况下独自运转；
- 清洁、维修或暂时不用吸尘器时，必须切断电源；
- 切断电源：不可拉电源线，应用手握住插头塑料部位拔下插头；
- 检查确认供电电压必须与吸尘器充电电压一致；
- 吸尘器的电源线，不要让它穿越锋利的物品，以免损坏电源线；
- 切忌将吸尘器浸入水中，避免接近发热器具或暴晒，以免发生火灾；
- 切勿拖拉电源线来移动充电座；
- 下列情形时，请不要使用吸尘器，并及时送至本公司指定的维修部检修
 1. 发生跌落并出现明显损坏或运转不正常；
 2. 电源线破损；
- 避免在吸入口堵住的状态下长时间运行，以免电机损坏及吸尘器发热变形。
- 搬运过程中不得按尘杯按钮，以防机器脱落轧伤。

SAFETY INSTRUCTIONS



- Do not place the appliance close to heat sources, radiation, or burning cigarette.
Do not use the appliance to remove the following objects:
 - 1) All liquids such as water and solvents.
 - 2) Lime, cement, ash and other construction dust and garbage.
 - 3) Hot objects, such as cigarette butts.
 - 4) Sharp objects, such as glass shards, etc.
 - 5) Inflammable and explosive articles, such as gasoline or alcohol products.
- Do not let children play with or operate the appliance to prevent accidents.
- Your appliance is an electric appliance: It must be used appropriately.
Do not leave the operating appliance unattended.
- The power must be turned off during cleaning, maintenance or when in storage.
- Do not pull the power plug to turn off the appliance.
Hold the plastic part of the plug to remove it from the power socket.
- The power supply voltage must correspond to that of the appliance charging voltage.
- Keep the power cord away from sharp objects to prevent it from being damaged.
- To prevent fires do not immerse the appliance in water, do not expose it to any heating appliances.
- Do not drag the power cord when moving the Charging station.
- In the case of below situations do not use the appliance and send it immediately to the nearest approved maintenance facility :
 - The appliance fell and consequently damaged.
 - The power cord is damaged.
- Stop operating the appliance if the suction inlet is blocked to prevent damages (such as overheating) to the motor or deformations to the vacuum plastic parts occasioned by overheating motor.
- Do not press the dust cup button during handling to prevent the machine from falling off.

保修须知

美的真空吸尘器严格遵照国家“三包”规定进行保修服务
用户在正常使用产品的情况下，提供相关免费维修服务



- 家庭整机保修两年，电机保修三年，充电产品的充电器、电池保修半年；
- 非家庭整机及其主要部件保修半年；
如：经营、商用、公司集体的产品。
- 保修期内用户可享受免费上门维修（特殊地区除外）服务；
“免费上门维修”限桶吸产品。
- 保修期界定：
 - 1.以有效保修凭证的开具日期作为保修期的起始日期；
 - 2.没有有效保修凭证的，按出厂日期后6个月作为保修期的起始日期；
 - 3.若既无有效保修凭证也无出厂日期的，则按该产品的最早上市日期后6个月作为保修期的起始日期；
 - 4.网购产品15天界定期以收货日期计算，后期保修可按发票日期计算。
- 保修期内维修更换的零部件归本公司所有，保修期外维修更换的零部件归用户所有；
- 其他事项按照国家“三包”规定执行；
- 凡属下述情况之一的，不在保修范围内：
 - 1.吸尘器附件（金属伸缩管/塑料接插管、软管、地刷、小附件等），耗材（滤芯、集尘袋等）和赠品；
 - 2.用户搬运、使用、维护、保管不当而损坏的；
 - 3.使用电压低于187V或者高于240V而损坏的；
 - 4.未按产品使用说明要求使用、维护、保养而造成损坏的；
 - 5.非本公司专业服务人员拆卸、维修的；
 - 6.因不可抗力（如雷电、火灾、地震、水灾等自然灾害）造成损坏的；
 - 7.产品超出保修期的；
 - 8.发票或保修卡上记录的型号或编号与商品实物不符合的。
- 以上情况我公司将实施收费维修，费用类型包括维修费、零部件费，具体费用标准在相关部门允许范围内。
- 由代理商、经销商、零售商自行承诺的额外服务与附加的非原厂配置赠品，由原代理商、经销商、零售商负责服务。

⚠ 注意

1. 本产品只限于家用，非家用出现任何问题本公司概不负责。
2. 如您发现产品需要服务时，请直接联系当地特约服务网点或我司服务热线400-8899-315。
3. 如来信，请留下您的联系电话，以便您能尽快得到回复。

WARRANTY INFORMATION

Midea appliance strictly comply with government policies .
Our company provide free maintenance service for the products operated under normal usage.

- The warranty period is two years for residential or home usage, three years for the motor, and six months for charging products and battery.
- The warranty period (including main components) is six months for non residential or non home usage. It applies to, but not limited, business offices, commercial entities, cleaning companies fleet of appliance.
- During the warranty period, you will benefit from no cost home maintenance services. (except for some special areas).the no cost maintenance is only applicable to the barrel products.
- **Definition of the warranty period:**
 - (1) The date for issuing the valid warranty certificate should be taken as the starting date of the warranty period.
 - (2) Without a valid warranty certificate, the first day after 6 months from the delivery date. should be taken as the starting date of the warranty period.
 - (3) If there is no valid warranty certificate, no packaging date, the first day after six months from market release should be taken as the starting date of the warranty period.
 - (4) Date is defined as being 15 days after receiving the products. the warranty period will start from that date.
- **The manufacturer is responsible for replacing the components during the warranty period.**
Components replacement is the responsibility of the user beyond the warranty period.
- **Other matters follow the government policies.**
- **The warranty does not apply to the following situations:**
 - (1) Appliance accessories (metal extension tube/plastic tube, hose, floor brush, small accessories, etc.), some parts (filter, dust bag, etc.) and gifts.
 - (2) The appliance is damaged due to improper usage (including storage) and operation by the user.
 - (3) The appliance is damaged due to incorrect voltage utilization (below 187 V or above 240 V).
 - (4) The appliance is damaged due to failure of following procedures as described in this manual for maintenance, cleaning and usage.
 - (5) Disassembly, repair by people other than the company's specialized service personnel.
 - (6) Damages due to natural causes (such as lightning, fire, earthquake, floods and other natural disasters).
 - (7) The warranty period has expired.
 - (8) The product type or serial number noted on the invoice or warranty card is not in conformity with the actual product.
- **If any of the above written situations arise, the user will solely bear all the charges related to the maintenance including the cost of spare parts. The cost is defined according to standard charges.**
- **Any commitment for extra services, additional gifts made by original agents, distributors or retailers are their sole responsibility and the manufacturer cannot be held responsible or liable.**

⚠ Caution

1. This product is limited for home usage and the company is not responsible for any problems caused by other usage.
2. For service, please directly contact the local special service outlet or our service hotline 400-8899-315.
3. Please indicate your contact phone number or email for faster response.

保修卡

WARRANTY CARD

保修卡	维修记录
用户姓名	日期
电话	故障内容
通讯地址(邮编)	产品型号
购买商店	处理内容
维修点	维修单位名称
编号	电话
发票号码	维修员签名
购买时间	

Warranty card	Record of Maintenance
User name	Date
Tel	Problem description
Contact address (Post code)	Product model
	Detailed information
Purchase location name and address	Service technician name
	Tel
Service/maintenance supplier	Service technician signature
Serial No.	
Invoice No.	
Purchase date	

tips 修理时需出具发票 Original proof of purchase (store invoice) is required for any service request.

⚠ 注意 Caution

1. 此保修卡在购买本公司产品时立即填写。
2. 此保修卡请妥善保管, 购买者不必将卡寄回本公司。
3. 维修时请携带此证及有效发票正本。

1. This warranty card should be immediately filled after purchase.
2. Keep this warranty card for your records; it does not need to be returned to Midea.
3. Bring / provide the warranty card and original invoice for service requests.

产品参数

产品技术参数

型号	额定电压	额定频率	额定功率	最大功率
C5-L121D	220V	50HZ	1100W	1200W

PRODUCT PARAMETERS

Product Technical Parameters

Model	Rated Voltage	Rated Frequency	Rated Power	Max Power
C5-L121D	220V	50HZ	1100W	1200W

